

Officewise

A guide to health and safety in the office

Developed by the Ergonomics Unit
Victorian WorkCover Authority
September 1997



VICTORIAN WORKCOVER AUTHORITY

Contributors to this publication

Ergonomics Unit, WorkSafe Victoria,
Victorian WorkCover Authority
Liz Pratt
Ros Kushinsky
Fiona Begg
Margaret Best

Risk and Injury Management Services
Chris Fitzgerald, Consultant Ergonomist

Comcare Australia

ISBN 07306 7995 0
Victorian WorkCover Authority

24th Floor, 222 Exhibition Street Melbourne 3000
Phone (03) 9641 1555
First published October 1995
Second edition May 1996
Third edition September 1997
Fourth edition October 2001

Setting up your workstation

Despite the availability and supply of adjustable workstation furniture and equipment, employees usually do not use these very well. The following checklist is a step-by-step approach designed to be used when employees are located at a new workstation or whenever their tasks are changed.

When setting up the position of this furniture and equipment it is important to try new positions to find the most comfortable arrangement for yourself. Give yourself a chance to get used to any changes, as it may take several hours or even days to determine the best position. Remember it may take several tries to get the best arrangement for yourself, but it is worth the effort – and if a change doesn't work, you can always reset it back to the previous position.

Chair

When adjusting your chair please refer to any instructions that are provided with the chair or have someone show you how to adjust it and use the controls. If there is no one available to assist you, work through this checklist with another person and observe each other's postures and position of the body.

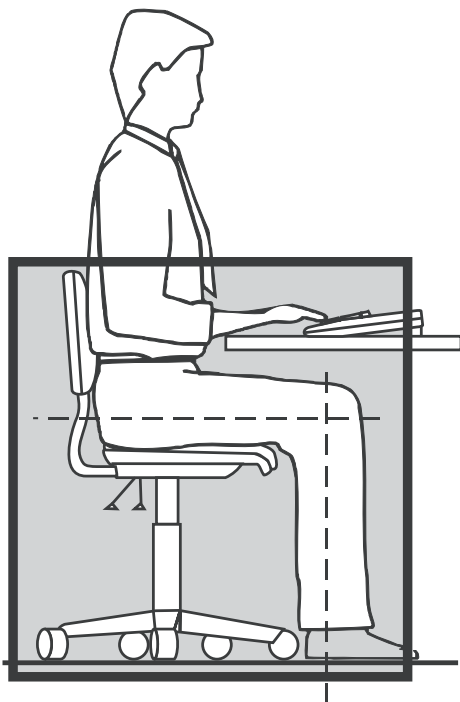

Figure 2: Align seat to thigh and lower leg positions

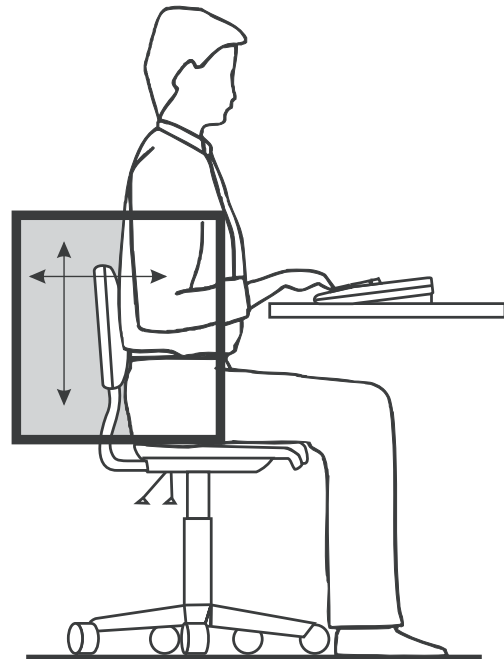

Figure 1: Adjust the height, forward/backward and back rest tilt position

Also, remember to try and avoid sitting for long periods of time. Some form of break from sitting every 20 to 30 minutes is helpful. Even getting up for 20 to 30 seconds to go to a printer or standing while talking on the telephone will provide some relief.

Seat:

Height Adjust chair height so the feet are comfortably flat on the floor, the thighs are approximately horizontal and the lower legs approximately vertical. Low heeled shoes will improve comfort of the legs with the chair at this height (see Figure 2).

Tilt (if available) Set to horizontal initially, although you may wish to adjust the tilt slightly forward to suit your comfort.

Back support:

Height Start by raising the back rest to its maximum height. Then sit in the chair and check the fit of the back rest to the curve of the lower back. If not comfortable, lower the height by several centimetres and try this position (see Figure 2).

Repeat this adjustment and try each new position until the most comfortable fit is found. Remember to get out of the chair to make this adjustment and ensure that the back rest supports the lower back and is not placed too low.

Forward/backward position Adjust the position of the back rest until a comfortable pressure is exerted on the low back area while seated in the usual working posture at the desk (see Figure 2).

The back rest position should not feel as though it pushes you out of the seat or that you have to lean back too far to reach it. There should be a two-finger clearance between the front of the chair and the back of the knee. Trial a number of different positions until the best fit is achieved.

Arm rests:

Arm rests are usually not recommended unless they are well out of the way of the desk. However, if your chair has arm rests make sure that they do not prevent you from getting as close to the desk as you require (see Figure 3) or that they impinge on your elbows while you are working (see Figure 4). If this is the case, either remove them by unscrewing them (see Figure 5), or replace them with a smaller or adjustable option.



Figure 3

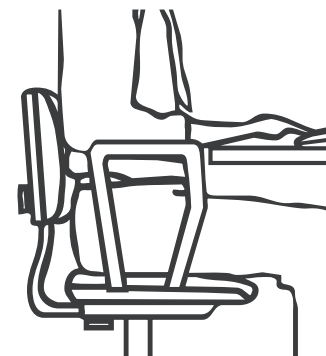

Figure 4



Figure 5

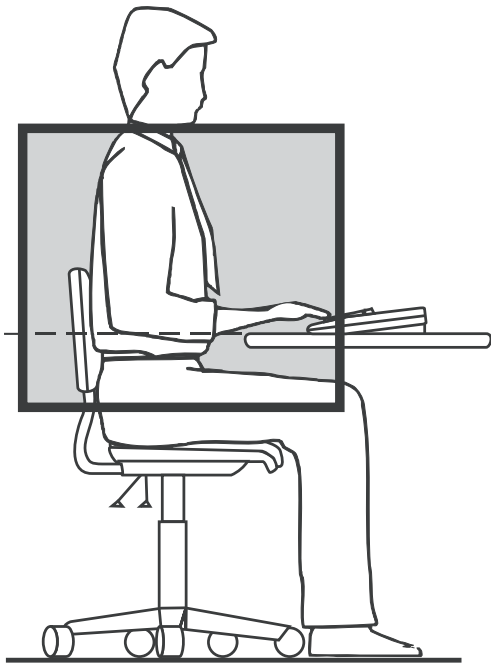

Figure 6

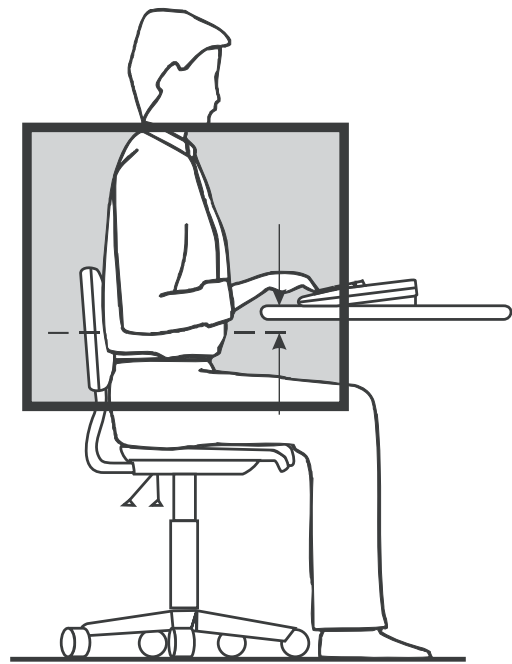

Figure 7

Desk

If you have a height-adjustable desk

Having first adjusted your chair to suit your body size, adjust the desk so the top surface is just below elbow height (see Figure 6). To determine your elbow height, relax your shoulders and bend your elbows to about 90 degrees and check the elbow height against the desk height (see Figure 7).

If you don't have a height-adjustable desk

If the chair has been adjusted and the desk is higher or lower than the elbow, other forms of adjustment will be required. Start by measuring the height difference between the desk and your elbow.

If the desk is too high

Raise the chair by the measured difference and use a foot rest. Set the foot rest platform so that it is the same as the measured difference (see Figure 8).

OR

Lower the desk by cutting the legs down by the measured difference.

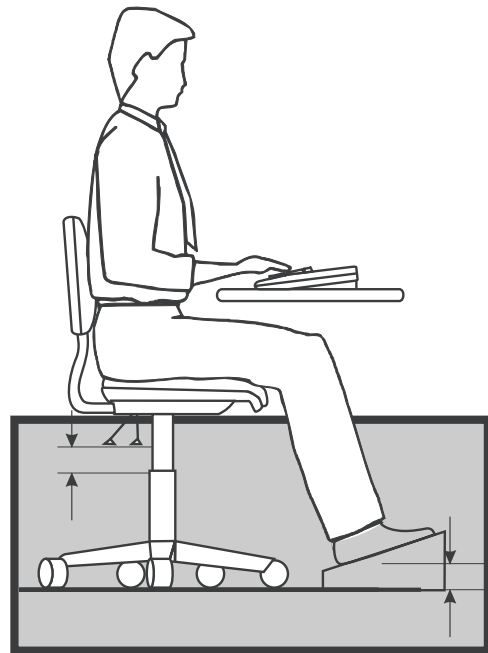

Figure 8

If the desk is too low

Raise the height of the desk by extending the leg length or sitting it on wooden blocks or something similar. Remember to ensure that any such changes are secure and stable.

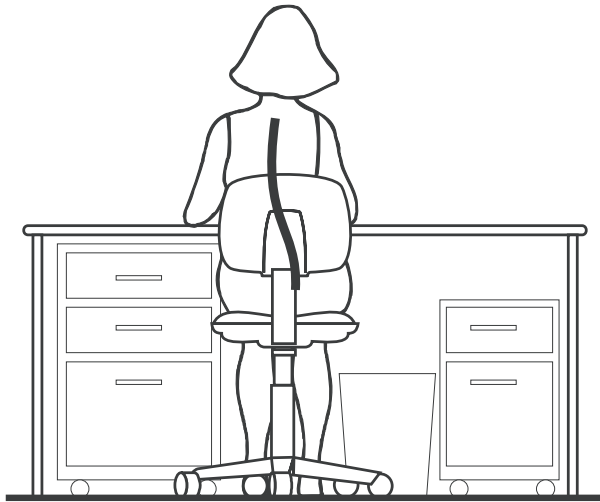

Figure 9

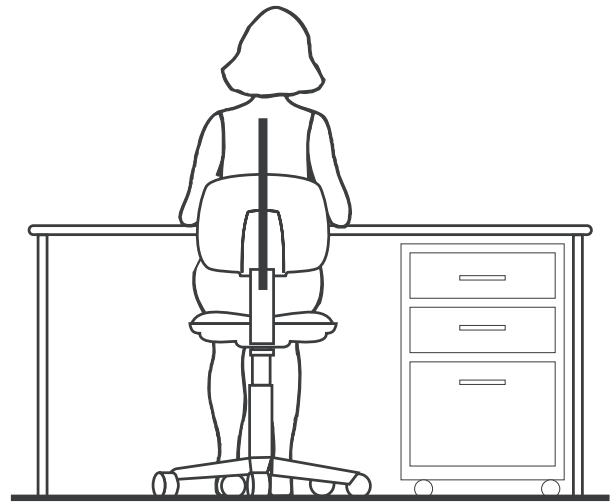

Figure 10

Clearance under the desk

General items, such as computer hard disc drives, boxes of documents or files, rubbish bins and mobile drawers should not be stored under desks where they will decrease or interfere with the space required for the legs. This may force the person to adopt a twisted or awkward posture of the spine (see Figures 9 and 10).

Drawers

Most commonly used items should be placed in the top desk drawer to improve access and reduce reaching and bending movements. Where drawers are fitted to the desk, equipment such as the keyboard and computer screen should be arranged on the desk so that the operator can sit comfortably in the leg-well space.

General storage on the desk

In trays. Place in-trays at the Outer Reach Sector (see Figure 11). In-trays should not be located above shoulder level.

Stationery. A variety of containers are available for mixed stationery items. These should also be stored at Outer Reach Sector (see Figure 11) or in the top desk drawer.

Reference books and folders. Large or heavy references such as telephone directories and manuals should either be stored within close reach of the seated user or in a nearby position where the user has to stand to access them. Handling of these items should not be conducted at the limit of a person's reach capacity while sitting as this can result in undue strain on the back, shoulder and arm muscles.

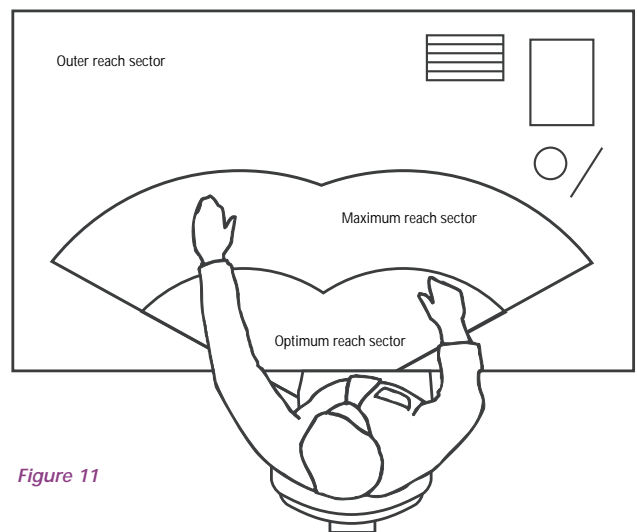

Figure 11

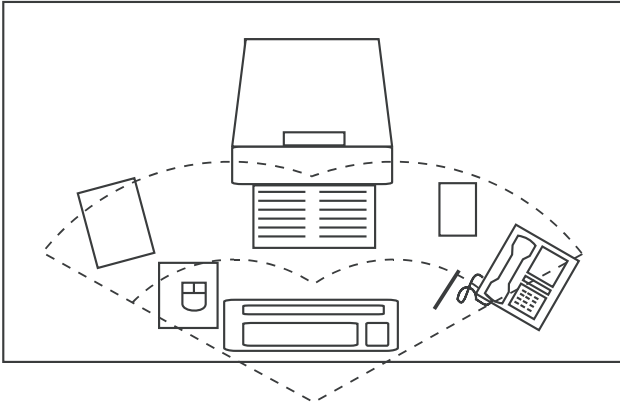

Figure 12

Keyboard

Angle

Tilt the keyboard, using the feet at the back, to suit your level of comfort. The common and preferred setting is where the feet are lowered so the keyboard sits flat on the desk.

Position on the desk

Place the keyboard as close to the front edge of the desk as is comfortable (see Figure 12). Do not place documents between the keyboard and the front edge of the desk while using the keyboard, as this increases

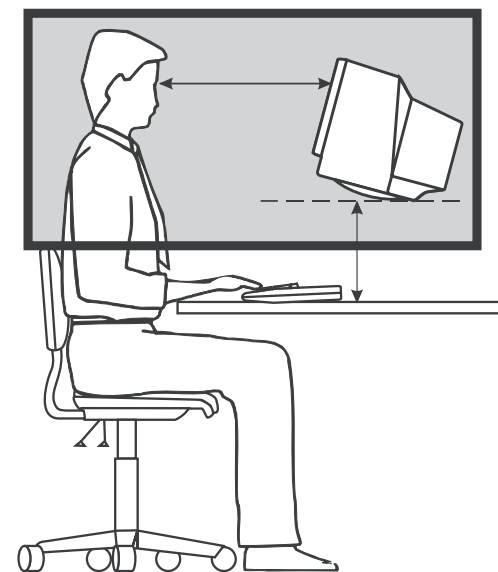

Figure 13

the reach distance to the keyboard and may result in excessive bending of the neck to look at the documents. Ensure that there is room to put the keyboard to one side when it is not in use.

Mouse

Place the mouse mat directly beside the end of the keyboard on your preferred side (see Figure 33). Use the mouse in this position and always aim to keep the mouse on the mat during use.

If you frequently use the mouse in your work you may wish to:

- learn to use it with both hands so that you can swap between the right and left sides for improved comfort
- set the tracking speed of the mouse to a setting that suits you
- maintain your mouse to keep it in good working order (for example, keeping it clean inside)
- where possible, try and avoid holding onto the mouse when not in use

VDU

The screen should be positioned once the chair and desk heights have been established.

Height

The screen should be positioned so that the top of the screen is level with, or slightly lower than, your eyes when you are sitting upright (see Figure 13). If the screen does not have a raising device such as a monitor stand, you may be able to use telephones books to raise the screen height on a temporary basis.

Distance from the eye

First place the screen so that it is approximately an arm's length away from the usual seated position of the user (see Figure 13). Trial this position and if necessary move it further away or closer as required.

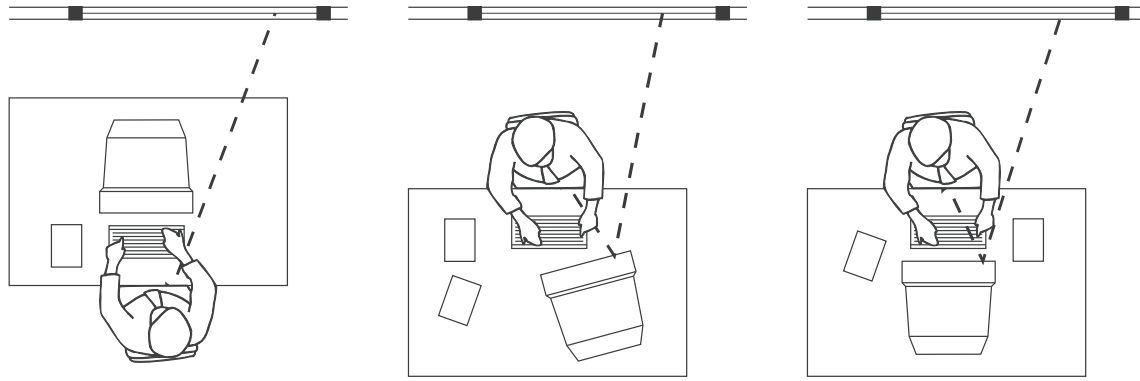

Figure 14: Unsuitable screen locations in relation to windows

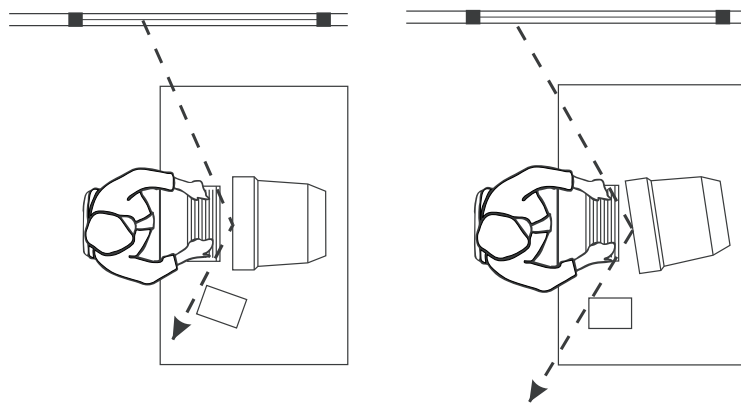

Figure 15: Suitable screen locations

Positioning the screen

The screen should be placed in front of the user to avoid glare or reflections from windows (see Figures 14 and 15).

For continuous or frequent data entry where the source document is observed more than, or the same amount as, the screen:

- place the screen slightly to one side so that the document holder is directly in front of the user – see Figure 16

OR

- place the document holder in a similar position to the screen where it is slightly to one side and the user looks evenly between the two – see Figure 17

For use where the screen is observed more than a source document or a source document is not used at all:

- place the screen directly in front of the user – see Figure 18

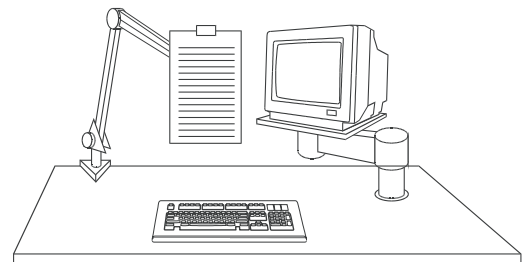

Figure 16

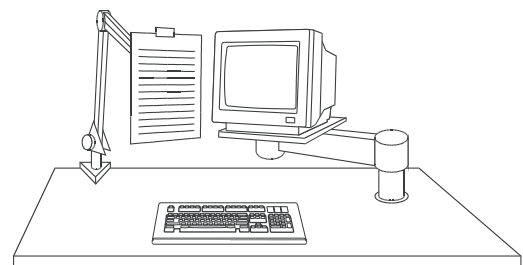

Figure 17

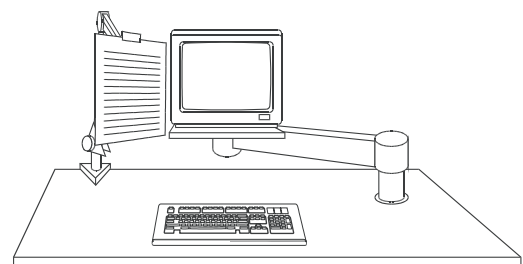

Figure 18

Document holder

The position of the document holder is dependent upon the needs of the user in viewing and reaching the documents and the type of document holder that is used.

An A-frame style bookrest that sits on top of the desk is the most practical and can be set at different angles. It is usually best placed so that it supports documents on an inclined angle between the keyboard and the screen.

A lever or swivel arm document holder suspends the document above the desk at eye level. Anchor it to the desk on either the left or right or the screen, according to your preference, and place it directly beside the screen.

Telephone

The telephone should be placed either within or at the limit of the Optimum Reach Sector, depending on the amount of use (see Figure 33). The placement should enable the user to operate the telephone without the need to move their trunk to grasp the handset or to operate the numeric and function buttons. Place the telephone on either side according to your preference, comfort and other equipment that is used.

When making a lot of calls, it may be best to place the telephone on the same side as the dominant hand so that this hand can comfortably operate the numeric and function buttons. When mostly receiving calls, it may be more comfortable to place it on the non dominant side.

Learn and utilise the functions of your phone, such as redial and the storage of commonly used phone numbers, to improve the efficiency of its use. Also, where the phone is used very often or for prolonged periods, consider the use of a headset.

Angled reading and writing surface

An angle board can improve neck comfort where a job involves a lot of reading and handwriting. It should be placed immediately in front of the user on top of the desk (see Figures 19 and 20).

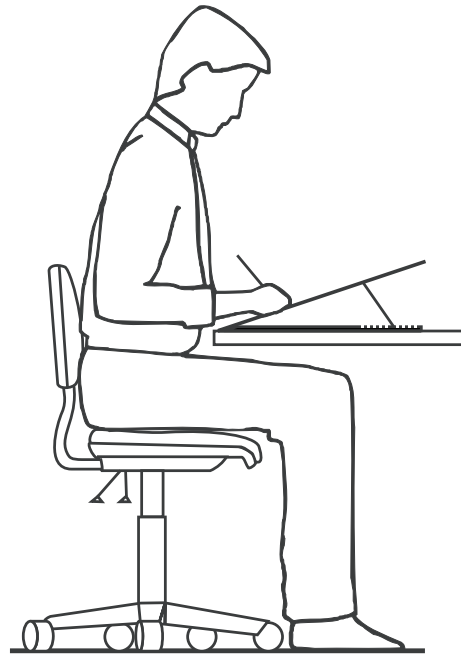

Figure 19

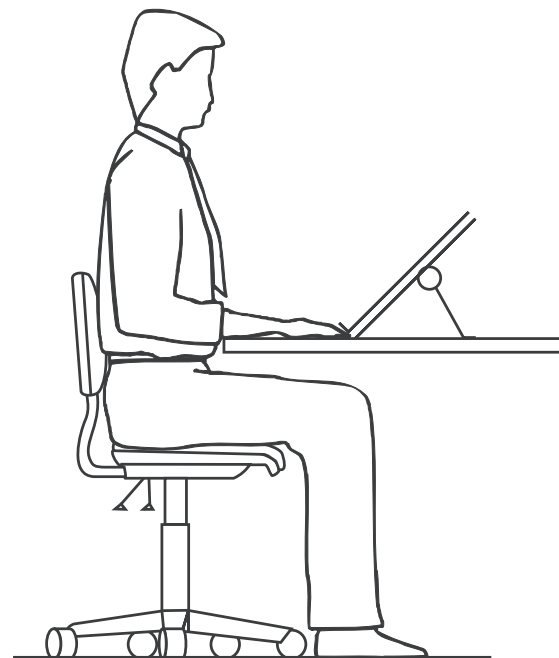

Figure 20

WorkSafe Victoria Offices

WorkSafe Victoria

WorkSafe Victoria offers a complete range of health and safety services:

- emergency response
- advice, information and education
- inspections
- licensing and certification
- publications.

For further assistance and information, contact any of the WorkSafe Victoria offices listed below.

Head office

Victorian WorkCover Authority
24th Floor
222 Exhibition Street
Melbourne Victoria 3000

GPO Box 4306
Melbourne Victoria 3001

Phone 9641 1555
Fax 9641 1222
Toll-free 1800 136 089

Local Offices

Ballarat	5337 1400
Bendigo	5443 8866
Dandenong	8792 9000
Geelong	5223 2300
Melbourne	9628 8115
Mildura	5021 4001
Mulgrave	9565 9444
Preston	9485 4555
Shepparton	5831 8360
Traralgon	5174 8900
Wangaratta	5721 8588
Warrnambool	5562 5600

Publications

Phone 9641 1333
Fax 9641 1330

Website

www.workcover.vic.gov.au

Email

info@workcover.vic.gov.au

WorkCover Advisory Service

24th Floor
222 Exhibition Street
Melbourne Victoria 3000

Phone 9641 1444
Fax 9641 1353
Toll-free 1800 136 089